



»» Mobile Column Lift
EHB® 1005 DC - wireless



- + Slim column design allows for best vision and accessibility
- + Driving components completely enclosed, maintenance-free
- + Battery-powered and radio-controlled, for flexible use independent from power supply
- + EasyCharge: simple and quick charging via one 230 V supply



Detachable wheel handle



LCD display

Technical Data – EHB1005 DC - wireless:

| | |
|--------------------------|--|
| Model / capacity: | Set of 4, 4 x 5,5 t = 22 t Set of 6, 6 x 5,5 t = 33 t |
| Load support: | Adjustable forks for wheels Ø 550 - 1140 mm Length of fork 300 mm |
| Lifting stroke: | 1750 mm (effective) |
| Lifting / lowering time: | Approx. 70 sec. |
| Operation: | Central LCD control panel at one column Fast / Slow speed Up / Down, All / Single / Pair Max. 10 columns per lift set |
| Control: | Wireless communication via radio control Continuous / softstart |
| Drive: | Electro-hydraulic |
| Power supply: | Batteries, total 24 V |
| Charging of batteries: | Connection 230 VAC, 1 charging cable per column |
| Travelling device: | 1 detachable wheel handle per lift set |
| Weight: | 400 kg per column |

Accessories:

- Wheel jack, spring loaded, at each column
- LCD display at each column

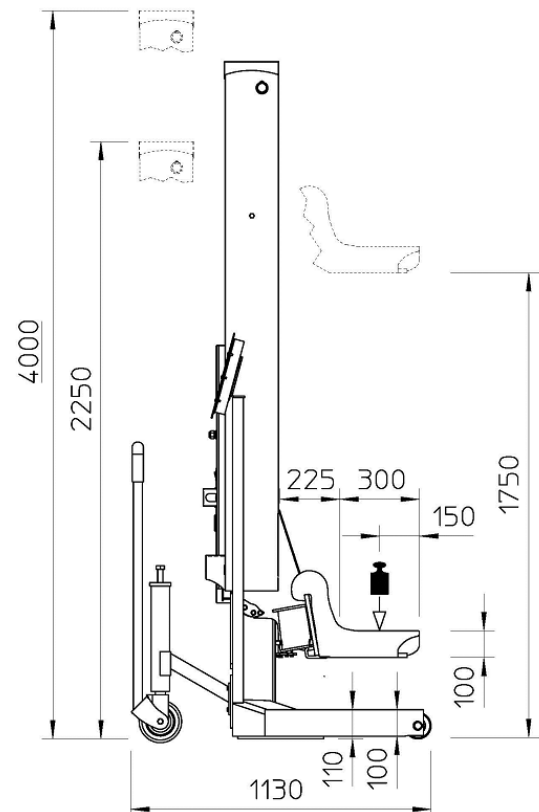

Finkbeiner

Walter Finkbeiner GmbH
 Alte Poststrasse 9 · 72250 Freudenstadt · Germany
 Tel +49 (0)7441 4031 · Fax +49 (0)7441 87778
 info@finkbeiner.eu · www.finkbeiner.eu

The Finkbeiner company
is certified by

