

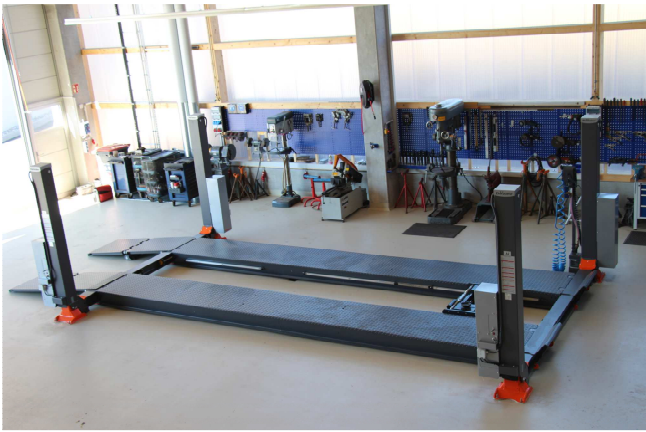

»»» 4-Post Lift
HDP12



Technical Data – 4-post lift HDP12:

Capacity:	12 t, 18 t with symmetric load
Lifting height:	1990 mm
Platform length:	6.5 m to 11.0 m
Platform width:	700 mm
Platform height:	240 mm
Width adjustable:	600 - 1300 mm inside
Lifting / lowering time:	Approx. 70 sec.
Operation:	Central at one column Via LCD display Fast and slow speed with softstart
Drive:	Electro-hydraulic Motor 2.2 KW per column
Connection:	230V / 1Ph / 16A at one column, for permanent charging of batteries
Power supply:	Batteries, 12V/50AH per column, deep cycle, maintenance-free

A modern workplace – clear and work-friendly

- + Best vision in the work space, as the columns move upwards
- + Movable platforms for different wheel tracks
- + Torsion-resistant platform profile with patented omega profile
- + Maintenance-free tube guiding of the lifting sledge
- + Insensitive hydraulic drive at each column

Accessories– 4-post lift HDP12:

- Ramps, foldable, hanging fixed on the lift
- Ramps, floor-mounted
- Lighting kit
- Pneumatic sockets
- Electric sockets 230 V
- Jacking beam, capacity 8 t

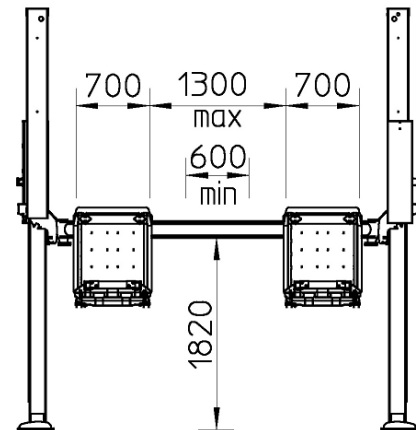

front view

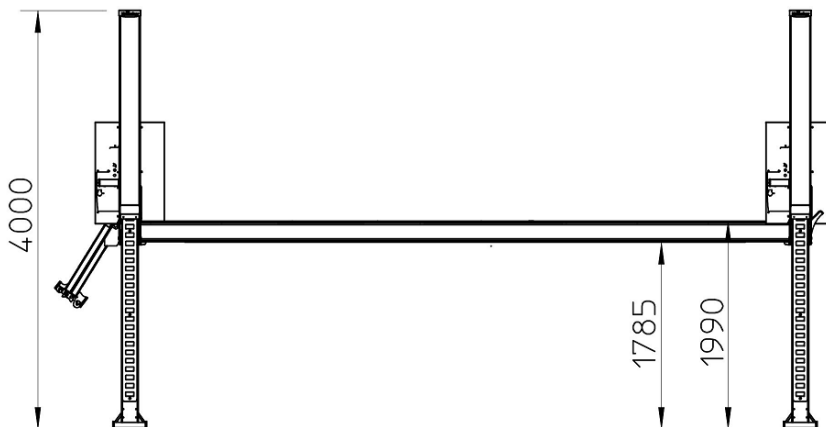

lateral view

Finkbeiner

Walter Finkbeiner GmbH
 Alte Poststrasse 9 · 72250 Freudenstadt · Germany
 Tel +49(0)7441-4031 · Fax +49(0)7441-87778
 info@finkbeiner.eu · www.finkbeiner.eu

The Finkbeiner company
is certified by

