

# OZZ XR3 P9" 65

88107 (black)

88108 (white)

## Before installation

1. Check the local laws and regulations and the region your vehicle may travel to for Auxiliary light before installation, ensure they are compliance.
2. Read all installation instructions.
3. Make sure the dimension and weight of the lamps and device are matched to your vehicle. See figure O1.
4. Slight moisture inside may occur, it will be removed out from the vent after 2-4 time working.
5. Working Voltage: 10-32V DC.

## Mounting

1. Place the nut on the bolt and hand-tighten it to hold the light in place. Use a wrench to fully tighten the nut, ensuring the light is securely mounted.
2. Connect black cable to ground (-).
3. Connect red cable to positive (+).
4. To synchronise multiple units (max 10 pcs) connect the green cables together, and keep connected otherwise units will fall out of sync.
5. To switch between day and night mode, apply the green cables to positive (+) for 1 second, and then release.
6. Use a stabilizer if it is needed for stabilization, see figure O2.

## Wiring connections & Functions

### 1. Wiring connections

Red : Positive, +  
 Black: Ground, -  
 Yellow: Amber position light, +  
 White: White position light, +  
 Green: Day/night mode/sync, +  
 Blue: Amber warning light, +  
 Beige: E-marked mode, +

When connecting, there are two modes to choose from: Boost mode and E-marked mode.

#### Boost Mode:

Connect the red cable to the vehicles positive terminal (pre-prepared connection in the DT contact).

#### E-marked Mode:

Connect the beige cable to the vehicles positive terminal.

#### Switching Between Modes:

To switch between Boost and E-marked modes, connect a separate switch with both the red and beige cables.

Note: The lamp is pre-configured for Boost mode. If you want to use the E-marked mode, you need to connect the beige cable instead of the red one. If both the red and beige cables are connected to the vehicles positive terminal, Boost mode will override.

### 2. Wiring Harness, 40A relay, 30A fuse.

**Please note:** Do not use the product if the lamp housing or lens is damaged upon removal from the packaging. Ensure the power is turned off during installation. The warranty is void if the product is mounted upside down or if the DT-connector is cutted.

Figure O1

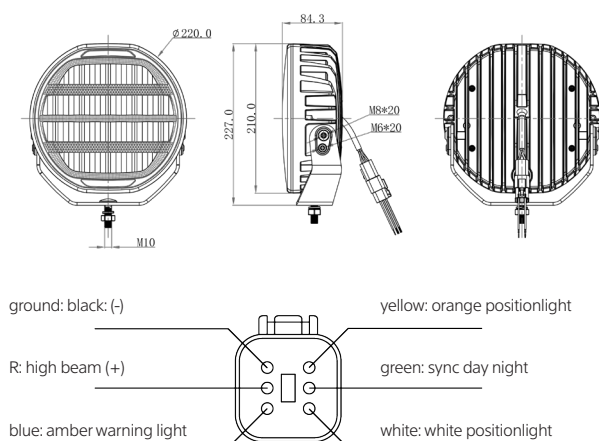

Figure O2

