

DUAL COLOUR 3+3 LED DUAL COLOUR LIGHTHEAD

WIRING

To Chassis Ground:..... **BLACK**

To+VDC for Warning Mode ① (fuse @ 1A):..... **RED**
Default Colour Mode - Colour 1

To+VDC for Warning Mode ② (fuse @ 1A):..... **WHITE**
Default Colour Mode - Colour 2

(To+VDC for Warning Mode ③:..... **RED+WHITE**)
Default Colour Mode - Colour 1 alt. 2

Order of Precedence: Mode ③ > Mode ① > Mode ② > Cruise Mode

To+VDC for Cruise Mode (fuse @ 1A):..... **GREEN**

For Synchronization and Flash Pattern:..... **YELLOW**

Connect **YELLOW** wires of all lightheads together for synchronization.
(All lightheads should be set to the same Flash Pattern)

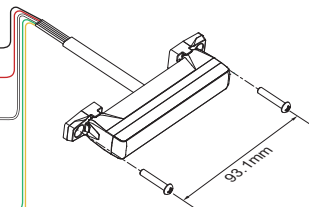

OPERATION

For Flash Pattern Selection:

Each Warning Mode may select and save one Flash Pattern. While activating a Warning Mode, momentarily apply **YELLOW** wire to +VDC:

- Once to next pattern.
- Quick three times to the default Flash Pattern (FP#1). (refer to Flash Pattern Chart)

For Simultaneous or Alternating Synchronization:

1. Apply +VDC to **RED** (or **WHITE** or **RED+WHITE**) and **YELLOW** wires simultaneously to enter **SETTING MODE**; the lighthead will display short flashes:
 - Single flash = Group 1
 - Double flash = Group 2
2. Remove **YELLOW** wire from +VDC then momentarily apply to +VDC again for more than 3 seconds to change Groups:
 - Lightheads of the same Group will flash together.
 - Lightheads of the different Group will flash alternately.
3. Save and exit **SETTING MODE** by disconnecting all power.

For Color Mode Setting:

1. Each Warning Memory may select and save one Colour Mode. Apply +VDC to **RED** (or **WHITE** or **RED+WHITE**) and **YELLOW** wires simultaneously to enter **SETTING MODE**; the lighthead will display its current Colour Mode:

- Single Colour flashing Color 1 = Color 1
- Single Colour flashing Color 2 = Color 2
- Dual Colour flashing Color 1 = Color 1 alt. 2
- Dual Colour flashing Color 2 = Color 2 alt. 2

2. Remove **YELLOW** wire from +VDC then momentarily apply to +VDC for less than 3 seconds to change Colour Mode.
3. Save and exit **SETTING MODE** by disconnecting all power.

Reset to Factory Default Settings:

1. Apply +VDC to **RED** (or **WHITE** or **RED+WHITE**) and **YELLOW** wires simultaneously to enter **SETTING MODE**;
2. Remove **YELLOW** wire from +VDC then momentarily apply to +VDC again for more than 5 seconds. The lighthead will display fast short flashes to signify restoring successfully.
3. Save and exit **SETTING MODE** by disconnecting all power.

Flash Pattern (Dual Colour)

1 Double [2Hz]	8 Double [SAE]	15 Single-Quad	22 Triple-Triple Fast
2 Single [2Hz]	9 Triple [SAE]	16 Single H/L	23 Quint-Triple
3 Triple [2Hz]	10 Quad [SAE]	17 Single-Triple-Quint	24 7-1 Flash
4 Quad [2Hz]	11 Quint [SAE]	18 Steady Scene	25 7-1 Flash#
5 Random	12 Mega	19 Single-Single	26 Quad-Single
6 Steady EF*	13 Giga	20 Double-Double	27 Quad-Single#
7 Single [SAE][CA13]	14 Ultra [SAE]	21 Triple-Triple Mid	28 Quint-Quint

FP#19-28 will always operate in dual colour.

* For use with external flash controller. # Inverted colour mode.

SINGLE COLOUR 6 LED SINGLE COLOUR LIGHTHEAD

WIRING

To Chassis Ground:..... **BLACK**

To+VDC for Warning Mode (fuse @ 2A):..... **RED**
Apply +VDC to **RED** wire for High Power Operation (100%).

For Low Power Operation:..... **WHITE**
Apply +VDC to **WHITE** wire while **RED** wire is activated for Low Power Operation (40%).

To+VDC for Cruise Mode (fuse @ 2A):..... **GREEN**
Order of Precedence: Warning Mode > Cruise Mode

For Synchronization and Flash Pattern:..... **YELLOW**

Connect **YELLOW** wires of all lightheads together for synchronization.
(All lightheads should be set to the same Flash Pattern)

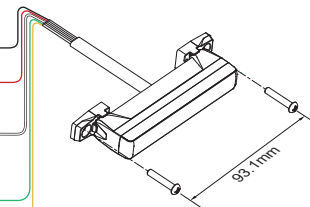

OPERATION

For Flash Pattern Selection:

Each Warning Mode may select and save one Flash Pattern. While activating a Warning Mode, momentarily apply **YELLOW** wire to +VDC:

- Once to next pattern.
- Quick three times to the default Flash Pattern (FP#1). (refer to Flash Pattern Chart)

For Simultaneous or Alternating Synchronization:

1. Apply +VDC to **RED** and **YELLOW** wires simultaneously to enter **SETTING MODE**; the lighthead will display short flashes:
 - Single flash = Group 1
 - Double flash = Group 2
2. Remove **YELLOW** wire from +VDC then momentarily apply to +VDC again for more than 3 seconds to change Groups:
 - Lightheads of the same Group will flash together.
 - Lightheads of the different Group will flash alternately.
3. Save and exit **SETTING MODE** by disconnecting all power.

Reset to Factory Default Settings:

1. Apply +VDC to **RED** and **YELLOW** wires simultaneously to enter **SETTING MODE**;
2. Remove **YELLOW** wire from +VDC then momentarily apply to +VDC again for more than 5 seconds. The lighthead will display fast short flashes to signify restoring successfully.
3. Save and exit **SETTING MODE** by disconnecting all power.

Flash Pattern (Single Colour)

1 Double [2Hz]	10 Quad [SAE]
2 Single [2Hz]	11 Quint [SAE]
3 Triple [2Hz]	12 Mega
4 Quad [2Hz]	13 Giga
5 Random	14 Ultra [SAE]
6 Steady EF*	15 Single-Quad
7 Single [SAE][CA13]	16 Single H/L
8 Double [SAE]	17 Single-Triple-Quint
9 Triple [SAE]	18 Steady Scene

* For use with external flash controller.

INSTALLATION

Universal Bracket (Multi-Angle)

NOTE:

Tighten the mounting bolts with the suggested range of torque value:
7.5~15 kgf-cm (6.5~13 lbf-in).

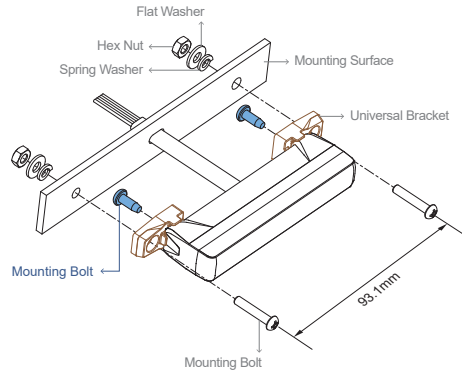

OR

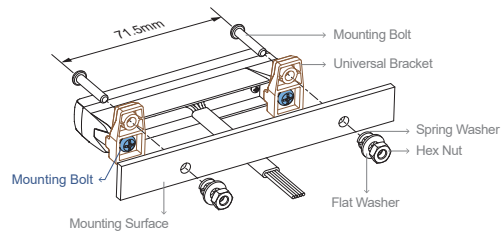

Adjustable Bracket (Optional)

The angle of lighthouse is adjustable up to 20 degree for optimum warning efficiency.

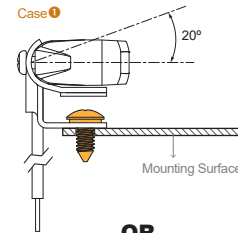

OR

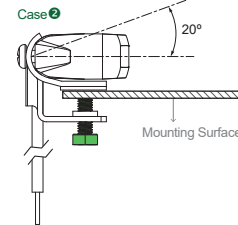

NOTE:

Tighten the mounting bolts with the suggested range of torque value:
7.5~15 kgf-cm (6.5~13 lbf-in).

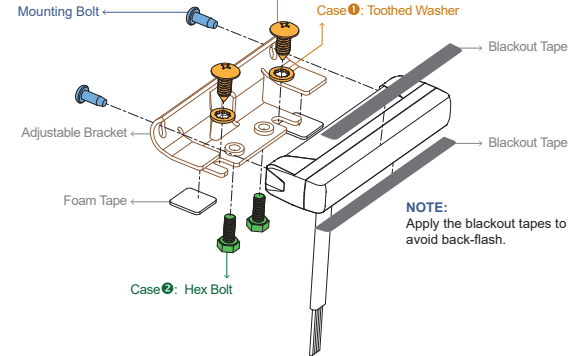

NOTE:
Apply the blackout tapes to avoid back-flash.

L-Bracket (Front / Rear)

NOTE:

Tighten the mounting bolts with the suggested range of torque value:
7.5~15 kgf-cm (6.5~13 lbf-in).

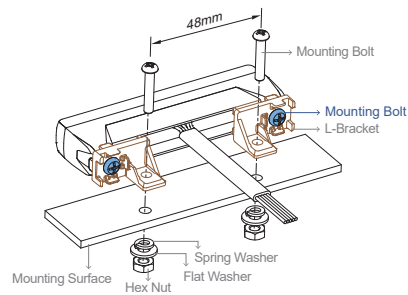

OR

