



**WARNING** -Before Installing This Product.

1. Verify all parts listed are in the box. If any parts are missing, please contact your selling dealer for assistance.
2. Read and understand all warnings and safety guidelines.
3. Inspect product for damage. If damage is found **DO NOT INSTALL!** please see your authorized dealer for warranty support.
4. Verify that your electrical system can support the specified voltage range for this product.
5. If you are not qualified to work on vehicle wiring systems, please seek professional assistance.



**INCLUDED :**

- 1 x LED Light bar
- 2x Stainless Steel Mounting Bracket
- 8 x 6mm x 15 bolts
- 8 x 6mm flat, lock washers and nuts
- 4 x 6mm x 30 mounting bolts

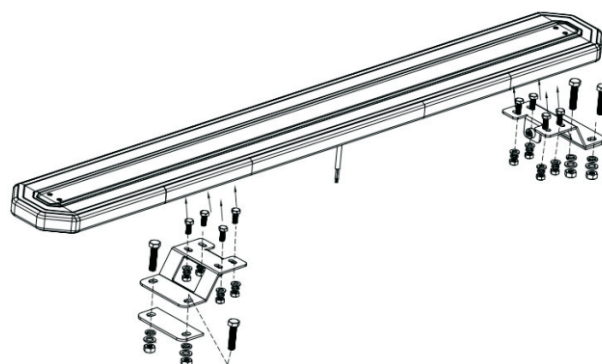

**INSTALLATION :**

The LED Light Bar is engineered to be mounted using the included mounting brackets and hardware for your specific type of installation. To ensure proper placement of your LED Light Bar, it is recommended that you measure and mark your preferred location prior to installation or seek professional installation assistance.

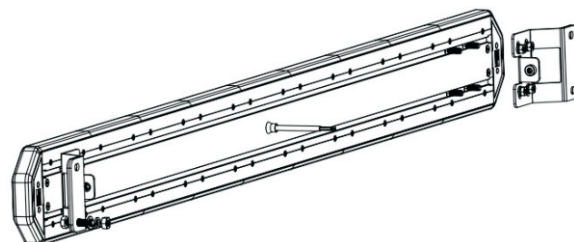

**FLASH PATTERNS :**

Pattern	FlashMode	Rate
1	Single Flash, ECE R65 Class 2 (by day)	125FPM
2	Single Flash, ECE R65 Class 1 (by night)	125FPM
3	Double Flash	125FPM
4	Triple Flash_Alt. Front&Back/All	22FPM
5	Triple Flash_Alt. Middle/Two Ends/All	22FPM
6	All(Single Flash) /All(Quadruple Flash)	53FPM
7	Single Flash:Alt. Left&Right Half	130FPM
8	Tracking Flash: Alt. In&Out	
9	Tracking Flash	
10	Cruise	
11	Center Arrow	
12	Left Arrow	
13	Right Arrow	



## MODE OPERATION









### Flash Pattern Selection:

The flash pattern selection can be selected through the wireless remote control or the yellow trigger wire on the lamp body. Apply yellow wire to +VDC for less than 1 sec to change pattern.

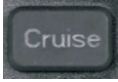
Wire	Function
Red	Positive
Black	Negative
Yellow	Flash Pattern Change(+)

- Less than 1s for next pattern
- 2-4s for previous pattern
- Over 5s for address cleared(pairing)

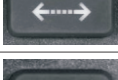
### WIRELESS REMOTE CONTROLLER:

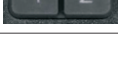
Button	Function	Specification
	Switch	Press the switch button, the wireless remote controller is turned on (the indicator light is on when charging)
	Address setting	First press to pair, Second press to erase the address of the paired lightbar. (This button has a memory function)
	Cruise	Press the button and the light will be in cruise state (solid burn)
	Flash pattern selection	Press the button to switch the previous /next mode
	Brightness selection	Press the button to switch by day/by night
	Left arrow	Press the button to left arrow
	Center arrow	Press the button to center arrow
	Right arrow	Press the button to right arrow
	Customize	This button allows user to set the shortcut mode, press the button for more than 2S, you can set the current mode as a shortcut function; press the button for less than 2S, switch the current mode to custom mode

### **WARNING**

1. Do not look directly into LEDs while in operation; may cause momentary blindness and/or eye damage.
2. Usage of this product is at sole risk and responsibility of the user. Please follow all local, State and Federal Laws.