

# **SDF104H**

## **Siren Amplifier**

— Installation & Operation Manual —



### **NOTICE TO INSTALLER**

Before installation and operation — read all instructions and warnings.  
Deliver this manual to the end user of this product.



# TABLE OF CONTENTS

<b>WARNING .....</b>	<b>1</b>
<b>CONTENTS .....</b>	<b>2</b>
<b>SPECIFICATIONS .....</b>	<b>2</b>
<b>WIRING.....</b>	<b>3</b>
<b>CONTROLLER FUNCTION .....</b>	<b>5</b>
<b>PROGRAMMING.....</b>	<b>5</b>
<b>INSTALLATION .....</b>	<b>9</b>

## WARNING

1. Proper installation of the product requires the installer to have a good understanding of automotive electronics, systems and procedures. It is essential to install the unit properly to ensure safe and reliable operation.
2. Please read through all instructions thoroughly and carefully before installing the unit.
3. Failure to follow these instructions could result in serious damage to the unit or vehicle and may void warranties.
4. The correct mounting and wiring is the key to the effectiveness of SDF104H.
5. Installers must read and follow instructions and warnings in the manual from the original manufacturer.
6. The operator should verify the siren system is fastened to the vehicle securely and is functioning properly. Failure to follow all safety precautions and instructions may cause property damage, injury, or death.
7. Ensure that any switch control panel is located in an area that allows both the vehicle and the control panel to be operated safely in any driving condition.

### **WARNING**

**Sound Hazard** - Sound level from a siren speaker (109dB at 2M) may cause hearing damage.



Do not operate the siren without adequate hearing protection for you and anyone in immediate vicinity.  
(Ref. OSHA 1910.95 for occupational noise exposure guidelines)

# CONTENTS

- ❶ Siren amplifier x 1 pc
- ❷ Control wire harness (30cm) x 1 pc
- ❸ Terminal block x 1 pc
- ❹ Sheet metal screws (ø3/16" x 3/4") x 4 pcs
- ❺ Tooth lock washers x 4 pcs
- ❻ Controller x 1 pc
- ❼ Controller clip x 1 pc
- ❽ Sheet metal screws (ø4 x 16mm) x 2 pcs
- ❾ Decal x 1 set
- ❿ Manual x 1 pc

## Accessories

- ❶ Extension cable (4m) x 1 pc
- ❷ RJ45 coupler x 1 pc

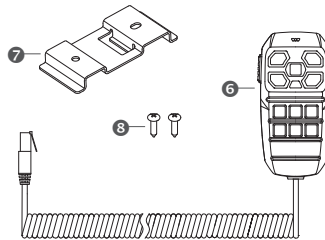
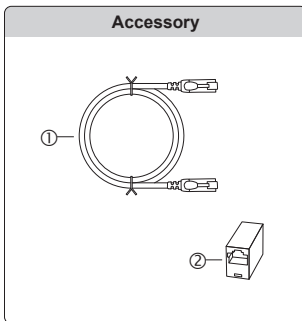
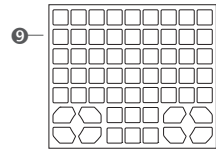
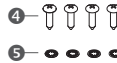
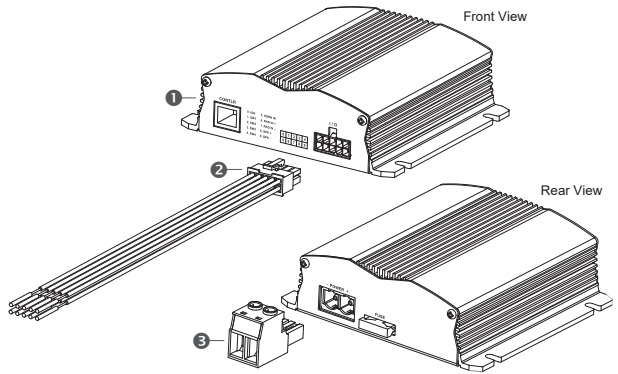

# SPECIFICATIONS

**Input Voltage:** 12~24VDC

**Siren Output Power:** 100 Watts

**Siren Output Load:** 100W-ACR 11Ω

**Siren Frequency:** 758Hz - 1587Hz; 447Hz - 596Hz (HI/LO)

**Max. Current:**

10A @ 12VDC / 5A @ 24VDC (w/o light control outputs)

30A @ 12VDC / 25A @ 24VDC (w/ 4x light control outputs)

**Standby Current:** 0 mA (w/o IGN wire) / <0.35 A (w/ IGN wire)

**Operating Temperature Range:** -30℃~65℃

**Light Controls:** 4x 5A light control outputs

**Fuse Ratings:** Built-in 5A blade fuse on each of the 4 outputs (under chassis);

15A blade fuse for the amplifier

**Dimensions(amplifier):** 126mm x 130.7mm x 41.6mm

**Dimensions(controller):** 63.9mm x 132mm x 26.9mm



# WIRING

## • Wiring diagram:

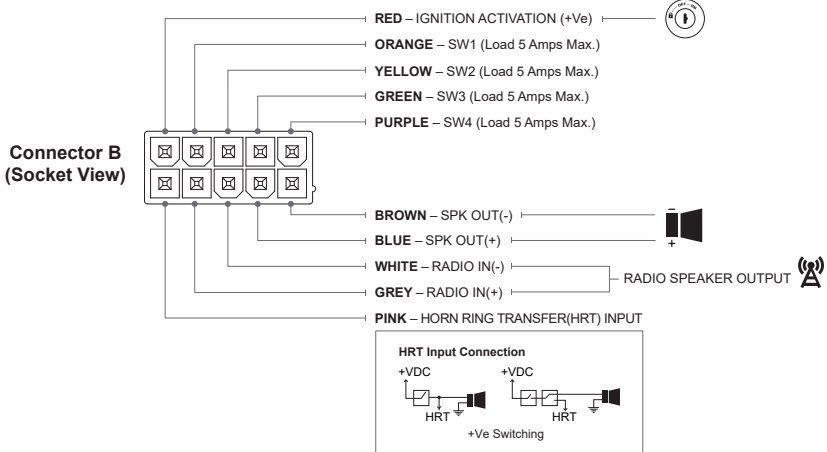
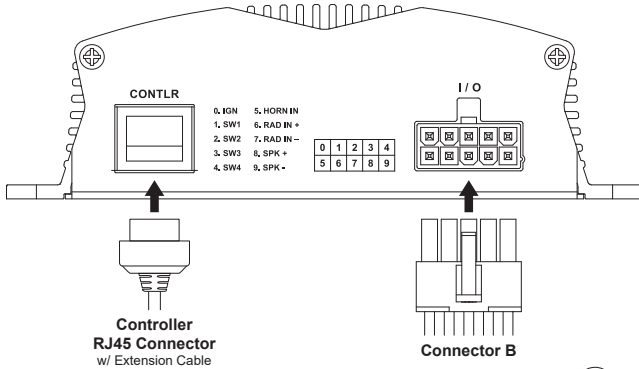
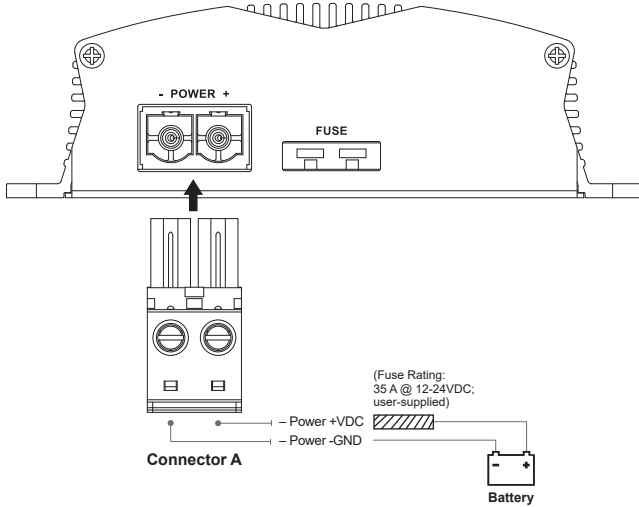

## ***Power Wire Terminal Block (Connector A)***

### **● *Power +VDC & -GND***

1. Connect to the positive (+) battery terminal. Fuse each wire independently @35 Amps (user-supplied).  
DO NOT install these fuses until the wiring for the entire system has been completed.
2. Connect to the vehicle's chassis ground (typically adjacent to the battery).
3. Plug the Connector A into the siren amplifier.

## ***Control Wire Harness (Connector B)***

### **● *Ignition Activation (IGN) input***

Apply +VDC continuously to **RED** wire to enable the siren system. Connect this wire to a positive circuit controlled by the vehicle ignition switch to allow the siren amplifier to be turned on & off together. The system does not operate without this Ignition Activation. DO NOT directly connect this wire to the battery as this may drain battery.

### **● *SW1 Output***

Connect to auxiliary device power up to 5 Amps max. or use as Lightbar function activation switch.

### **● *SW2 Output***

Connect to auxiliary device power up to 5 Amps max. or use as Lightbar function activation switch.

### **● *SW3 Output***

Connect to auxiliary device power up to 5 Amps max. or use as Lightbar function activation switch.

### **● *SW4 Output***

Connect to auxiliary device power up to 5 Amps max. or use as Lightbar function activation switch.

### **● *Speaker Out***

Connect the **BLUE** (SPK+) and **BROWN** (SPK-) wires to one 100W 11-ohm impedance speaker.

### **● *Radio Re-broadcast***

Connect **WHITE** and **GREY** wire to the speaker output of a radio console.

### **● *Horn Ring Transfer (HRT) input***

Apply +VDC continuously to **PINK** wire for Air Horn tone.

## CONTROLLER FUNCTION

Before any operation, apply positive voltage to the IGN (Ignition) wire at the rear to power-up the unit.

**PTT:** Activate Microphone for PA Broadcast through the siren speaker. This Button overrides all other acoustic function (i.e. Air Horn, Siren Tone and Radio Rebroadcast) while it is activated.

**Code 1, 2, 3:** Each Code button (**Code 1**, **Code 2**, **Code 3**) may be programmed to turn on and off switch button controls (**SW1~SW4**) and/or **SIREN** button together. These buttons may still be operated independently. (See "PROGRAMMING" section for more details) By default, **Code 1~3** will operate with **SW1~3** respectively with an additional **SIREN** on **Code 3**.

**MAN:** When the Siren Tone is not activated, this button generates Manual WAIL Tone that will ramp up to sustain a specific pitch until released (stopped immediately). When the Siren Tone is activated, press this button to cycle through all the tones in the tone cycle. (For available Siren Tone Cycles, see "PROGRAMMING" section for more details)

**HORN:** Momentarily activate the Air Horn Tone when it is pressed. This tone will override all other Siren Tones and Radio Rebroadcast while it is activated. This function can also be activated through the HRT input wire at the rear.

**SIREN:** Activate Siren Tone. (To set Siren Tone, See "PROGRAMMING" section for more details) This Button will de-activate the Radio Rebroadcast upon activation. It may be interlocked by **SW1**. (See "Siren Interlock / Horn Disable Setting" section for more details)

**RADIO:** Activate Radio Rebroadcast through the siren speaker. This button will de-activate the Siren Tone upon activation.

**SW1:** Activate SW1 Output; It may be used for the primary warning light and interlocking **SIREN**, **SW2**, **SW3** and/or **SW4**. (See "Siren Interlock / Horn Disable Setting" section for more details)

**SW2:** Activate SW2 Output.

**SW3:** Activate SW3 Output.

**SW4:** Activate SW4 Output.

**NOTE:** **SW1~SW4** buttons can be programmed for three operating modes such as ON/OFF, Momentary or Timer (10 seconds) Switch. (See "PROGRAMMING" section for more details)

## PROGRAMMING

<IMPORTANT> When entering a setting mode, if any of the button type is not in its default setting (ON/OFF), an auto-clearing will be performed with a full blinking of the controller. Re-do each step 1 to re-enter that setting mode again.

### Tone Cycle Setting

The Siren may be set to different tone setting according to your usage and application needs.

1. Press and hold **PTT**, **MAN** and **Code 2** for 5 seconds to enter *Tone Cycle Setting*. **Code 2** will blink to indicate that you are in *Tone Cycle Setting*.
2. While in *Tone Cycle Setting*, press **MAN** (-) or **HORN** (+) buttons to switch between different tone cycles. (See Siren Tone Cycle Chart) The setting is indicated with **RADIO**, **SW1**, **SW2**, **SW3** and **SW4** buttons. (See Indication Chart: Tone Cycle)

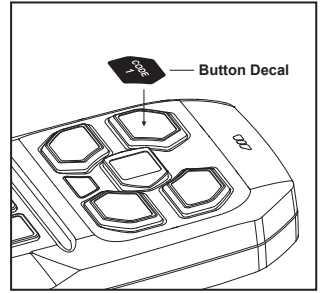

**NOTE:** The controller is shipped without any button decals installed. Place the proper decal onto each button.

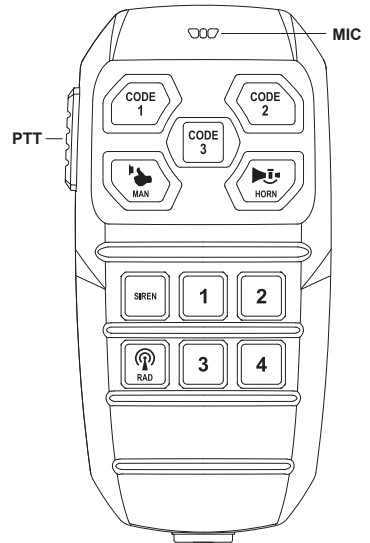

3. Once set, press **PTT** and **HORN** buttons for 5 seconds to save and exit *Tone Cycle Setting*. **Code 2** will stop blinking to indicate that you have exited.

INDICATION CHART: TONE CYCLE									
#	COUNTRY	STONE	FREQUENCY(Hz)	CYCLE/MINUTE	SW1	SW2	RADIO	SW3	SW4
1 (SAE default)	INTERNATIONAL	STANDARD	761-1592	WAIL 12 C/M	○	○	○	○	○
			761-1592	YELP 158 C/M					
2	INTERNATIONAL	STANDARD	761-1592	YELP 158 C/M	○	○	○	○	●
			761-1592	PHASER 886 C/M					
3	INTERNATIONAL	STANDARD	761-1592	PHASER 886 C/M	○	○	○	●	○
			450-598	HILO 40 C/M					
4	INTERNATIONAL	STANDARD	450-598	HILO 40 C/M	○	○	○	●	●
			761-1592	PHASER 886 C/M					
5	INTERNATIONAL	STANDARD	761-1592	WAIL 12 C/M	○	○	●	○	○
			761-1592	YELP 158 C/M					
			761-1592	PHASER 886 C/M					
6 (ECE default)	INTERNATIONAL	STANDARD	761-1592	WAIL 12 C/M	○	○	●	○	●
			761-1592	YELP 158 C/M					
			450-598	HILO 40 C/M					
7	INTERNATIONAL	STANDARD	761-1592	WAIL 12 C/M	○	○	●	●	○
			761-1592	YELP 158 C/M					
			450-598	HILO 40 C/M					
			761-1592	PHASER 886 C/M					
8	FRANCE	GENDARMERIE	435-733	HILO 55 C/M	○	○	●	●	●
9	FRANCE	POLICE	435-580	HILO 55 C/M	○	●	○	○	○
10	FRANCE	AMBULANCE	421-516-421	HILO 30 C/M	○	●	○	○	●
11	FRANCE	POMPIERS	435-488	HILO 27 C/M	○	●	○	●	○
12	FRANCE	UMH	435-649	HILO 55 C/M	○	●	○	●	●
13	GERMANY	STADT	432-575	HILO 40 C/M	○	●	●	○	○
		LAND	362-484	HILO 40 C/M					
14	AUSTRIA	POLICE	432-575-432-575- 432-575-432-575	HILO 25 C/M	○	●	●	○	●
15	AUSTRIA	AMBULANCE	524-393-524-393	HILO 17 C/M	○	●	●	●	○
16	AUSTRIA	FIREBRIGADE	393-524-393-524	HILO 17 C/M	○	●	●	●	●
17	AUSTRIA	MAGISTRATE	524-393-524	HILO 18 C/M	●	○	○	○	○
18	ITALY	POLICE	466-620	HILO 40 C/M	●	○	○	○	●
19	ITALY	AMBULANCE	392-659-392-659	HILO 40 C/M	●	○	○	●	○
20	ITALY	AMBULANCE 2	761-1592	WAIL 12 C/M	●	○	○	●	●
			761-1592	YELP 158 C/M					
			392-659-392-659	HILO 40 C/M					
21	NETHERLANDS	POLICE	373-500	HILO 33 C/M	●	○	●	○	○
22	NETHERLANDS	POLICE 2	373-500	HILO 33 C/M	●	○	●	○	●

○ : Green      ● : Red

## Volume Adjustment

PA, Siren and Radio Re-broadcasting may be set to different Volume Level (total of 8 levels, default at 8).

1. Press and hold **PTT**, **MAN** and **Code 1** for 5 seconds to enter *Volume Adjustment Setting*.
2. **Code 1** will blink to indicate that you are in *Volume Adjustment Setting*; press **SW1**, **SIREN**, or **RADIO** buttons for PA, Siren or Radio Re-broadcasting respectively.
3. Once a subject is selected, press **MAN** (volume -) or **HORN** (volume +) to adjust its volume level. Volume level setting is indicated with **SW2**, **SW3** and **SW4** buttons. (See Indication Chart)
4. Once set, press **PTT** and **HORN** buttons for 5 seconds to save and exit *Volume Adjustment Setting*. **Code 1** will stop blinking to indicate that you have exited.

INDICATION CHART			
#	SW2	SW3	SW4
1	○	○	○
2	○	○	●
3	○	●	○
4	○	●	●
5	●	○	○
6	●	○	●
7	●	●	○
8	●	●	●

○ : Green      ● : Red

## Siren Interlock / Horn Disable Setting

1. Press and hold **PTT**, **MAN** and **SIREN** for 5 seconds to enter *Siren Interlock / Horn Disable Setting*. **SIREN** will blink to indicate that you are in *Siren Interlock / Horn Disable Setting*.
2. While in *Siren Interlock / Horn Disable Setting*, press **RADIO** or **SW1** or **SW2** or **SW3** or **SW4** buttons to switch between different settings. (See Indication Chart: Siren Interlock / Horn Disable)

INDICATION CHART: SIREN INTERLOCK / HORN DISABLE			
BUTTON	○ (SAE default)	● (ECE default)	◐ (Green & Red)
RADIO	NO INTERLOCK	SIREN INTERLOCK BY SW1	SIREN INTERLOCK BY SW1 (w/ Auto ON)
SW1	ENABLE HORN/MAN	DISABLE HORN/MAN	
SW2	NO INTERLOCK	SW2 INTERLOCK BY SW1	
SW3	NO INTERLOCK	SW3 INTERLOCK BY SW1	
SW4	NO INTERLOCK	SW4 INTERLOCK BY SW1	

○ : Green      ● : Red      ◐ : Green & Red

3. Once set, press **PTT** and **HORN** buttons for 5 seconds to save and exit *Siren Interlock / Horn Disable Setting*. **SIREN** will stop blinking to indicate that you have exited.

## Code Button Combo Setting

**Code 1**, **Code 2** and **Code 3** buttons may be programmed to turn on and off switch button controls (**SW1~SW4**) and/or **SIREN** button together.

1. Press and hold **PTT**, **MAN** and **RADIO** for 5 seconds to enter *Code Button Combo Setting*. **RADIO** will blink to indicate that you are in *Code Button Combo Setting*.
2. While in *Code Button Combo Setting*, press and select one of **Code 1/Code 2/Code 3** buttons, and then press **SW1~SW4** and **SIREN** to add it into combination (indicated in Red); press these buttons again to remove from combination (indicated in Green).
3. Repeat step 2 until all **Code 1~Code 3** buttons are set.
4. Once set, press **PTT** and **HORN** buttons for 5 seconds to save and exit *Code Button Combo Setting*. **RADIO** will stop blinking to indicate that you have exited.

**NOTE:** Momentary switch will not be applied when it is activated by **Code 1~ Code 3** buttons.

## SW Button Type Setting

<IMPORTANT> Only alter the SW Button Type AFTER you have done setting other settings (i.e. Volume, Tone and Code1/2/3 Combo). SW Button Type will always revert to default (ON/OFF) whenever entering/re-entering a setting mode.

**SW1~4** each may be set as a ON/OFF switch, a Momentary switch or a Timer switch.

1. Press and hold **PTT**, **MAN** and **Code 3** for 5 seconds to enter *SW Button Type Setting*.
2. If any of the button type is not in its default setting (ON/OFF), an auto-clearing will be performed with a full blinking of the controller.
3. **Code 3** will blink to indicate that you are in *SW Button Type Setting*; the button type of each **SW1~4** button is indicated with its LED colour. (See the table below for SW button types)
4. Momentarily press each button to change its type.
5. Once set, press **PTT** and **HORN** buttons for 5 seconds to save and exit *SW Button Type Setting*. **Code 3** will stop blinking to indicate that you have exited.
6. Disconnect all power and power up again to apply the change.

LED Status	SW Button Type
Red	ON/OFF (default)
Green & Red	TIMER (10 seconds)
Green	MOMENTARY

# INSTALLATION

## Mounting

### • Siren amplifier

1. Select a location that is not exposed directly to weather elements, such as the driver compartment firewall, below the seat, or in the trunk; avoid any interference of air bag deployment.
2. Using the siren amplifier as a template, mark four mounting holes to be drilled.
3. Drill four mounting holes for sheet metal screw.
4. Install the siren amplifier with provided sheet metal screws and tooth lock washers.

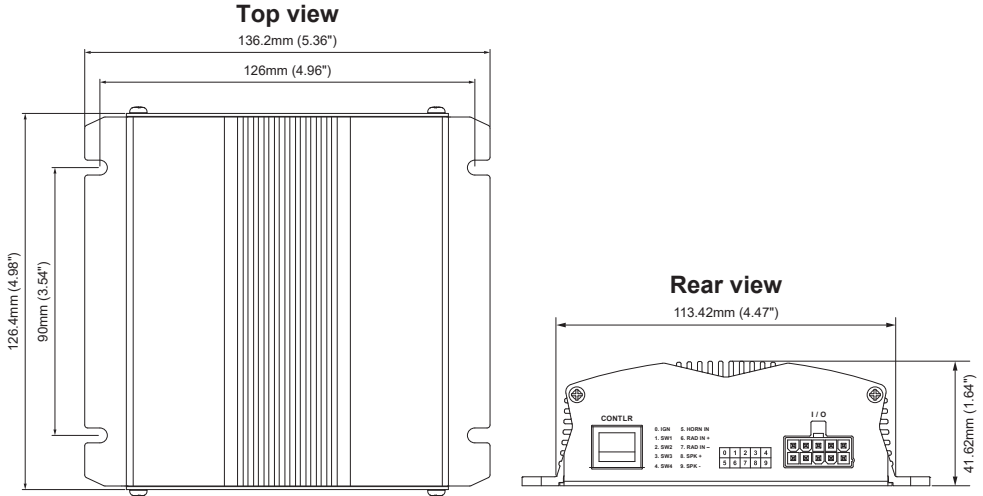

### • Controller clip

1. Select a location where is convenient to the operator; avoid any interference of air bag deployment.
2. Using the mounting clip as a template, mark the two holes to be drilled.
3. Drill two mounting holes for sheet metal screws.
4. Install the microphone clip with provided sheet metal screws.

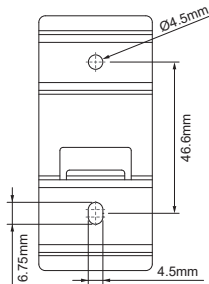

## WARNING



**PINCH HAZARD** - Steel, iron and/or other ferrous objects may be attracted suddenly and forcefully to the magnets, creating the risk of pinch-type injuries. Keep all mild steel and iron tools and equipment well away from the magnets at all times.

**IMPORTANT!** - Be certain to keep the controller away from the mounting location until you've cleaned up any metal shavings or other debris.

