

SW833

Installation & Operation Manual

— Control Panel 8+2 Outputs - 3 Inputs —



Table of Contents

Warning & Precautions

Warning & Precautions	2
-----------------------------	---

Chapter 1: Contents & Specifications

1-1 Contents	3
1-2 Specifications	3

Chapter 2: Installation

2-1 Mounting	4
2-1-1 Screw Mount Bracket	4
2-1-2 Suction Cup Mount	4
2-1-3 Power Module	5
2-1-4 Placement of Decals	5
2-2 Wiring	6
2-2-1 Power Module	6

Chapter 3: Programming & Operation

3-1 General Operation for Programming Mode	7
3-2 Standby Mode	9
3-3 Default Configuration of Buttons	9
3-4 Scene 1 and Scene 2 Controlled by B5 and B6	11
3-5 Programming Mode 1	12
3-6 Programming Mode 2	19
3-7 Button Combo: Group 1	23
3-8 Button Combo: Group 2	23
3-9 Button Combo: Group 3	23

Warning & Precautions

NOTICE TO INSTALLER

Before installation and operation – read all instructions, warnings and precautions thoroughly and carefully.

Deliver this manual to the end user of this product.

1. Failure to follow these instructions could result in serious damage to the unit or vehicle and may void warranties.
2. Proper installation of the product requires the installer to have a good understanding of automotive electronics, systems and procedures. It is essential to install the unit properly to ensure safe and reliable operation.
3. Do not install this product or route any wires in the air bag deployment zone of your vehicle. Equipment mounted or located in air bag deployment zones will damage or reduce the effectiveness of the air bag, or become a projectile that could cause serious personal injury or death. Refer to your vehicle owner's manual to learn the air bag deployment zones for the vehicle.
4. A properly-rated fuse must be installed as close to the battery as possible to protect the wires.
5. The same applies to any devices controlled by the installed device.
6. Ensure that none of the vehicle's original controls will be affected by the installed device.
7. Ensure that any unit is located in an area that allows both the vehicle and the control panel to be operated safely in any driving condition.

Chapter 1: Contents & Specs

1-1. Contents

❶ Power Module	x 1 pc
❷ Controller	x 1 pc
❸ RJ45 Cable (4m)	x 1 pc
❹ Terminal Block	x 1 pc
❺ Self-drilling Screw (#8 x 1")	x 4 pcs
❻ 6-Pin Wire Harness	x 1 pc
❼ Adjustable Bracket (based on the model ordered)	
A1 Suction Cup Bracket	x 1 pc
A2 Suction Base	x 1 pc
B1 Screw Mount Bracket	x 1 pc
B2 Self-drilling Screw (Ø4 x 15mm)	x 2 pcs
❽ Decals	x 1 set
❾ Manual	x 1 pc

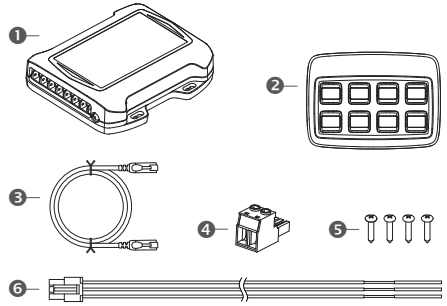

❼ Adjustable Bracket

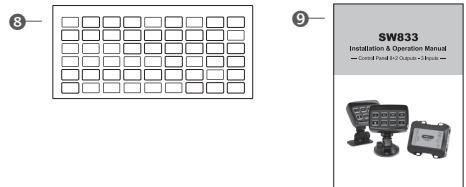
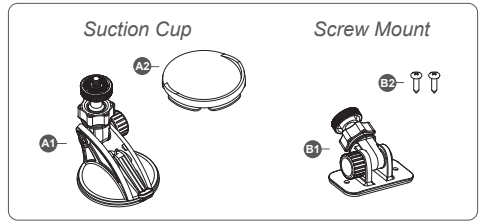

1-2. Specifications

1-2-1. Controller

Operating Voltage: 10~30VDC

Operating Temperature: -40°C~60°C

Dimensions: 68.8mm x 95mm x 25.5mm

1-2-2. Power Module

Number of Positive Outputs: 8

Number of Negative Outputs: 2

Max Current / Positive Outputs: 1x 15A, 2x 10A, 1x 10A (for Output 4~8)

Max Current / Negative Outputs: 2x 2A

Fuse Rating: 50A (user-supplied)

Dimensions: 100.5mm x 91.6mm x 25mm

Chapter 2: Installationa

2-1. Mounting

2-1-1. Screw Mount Bracket

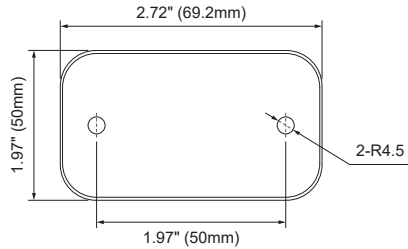
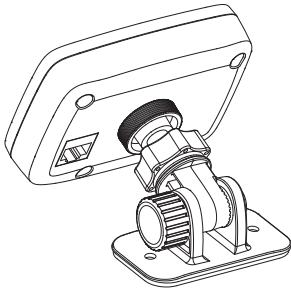

1. Choose a desired place for installation.
2. Use the base as the template to locate and mark two mounting holes on the mounting surface.
3. Secure the bracket with the two $\text{Ø}4$ self-drilling screws supplied.
4. Assemble the controller with the bracket by tightening the knurled knob in a firm way.
5. Adjust the bracket at an angle most convenient to your operation.

2-1-2. Suction Cup Bracket

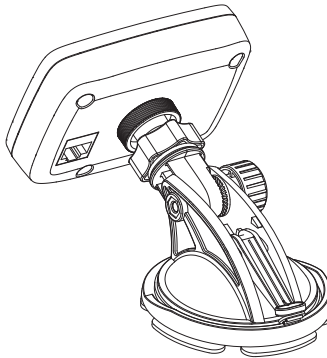

1. Choose a desired place for installation.
2. Press the suction cup to install the controller on the windshield directly. Or assemble the adhesive base at the bottom of the suction cup and follow the instructions below.
3. Mount the suction cup onto the mounting surface and allow the adhesive to set for at least 24 hours.
4. Assemble the controller on the bracket by tightening the knurled knob in a firm way.
5. Adjust the bracket at an angle most convenient to your operation.

2-1-3. Power Module

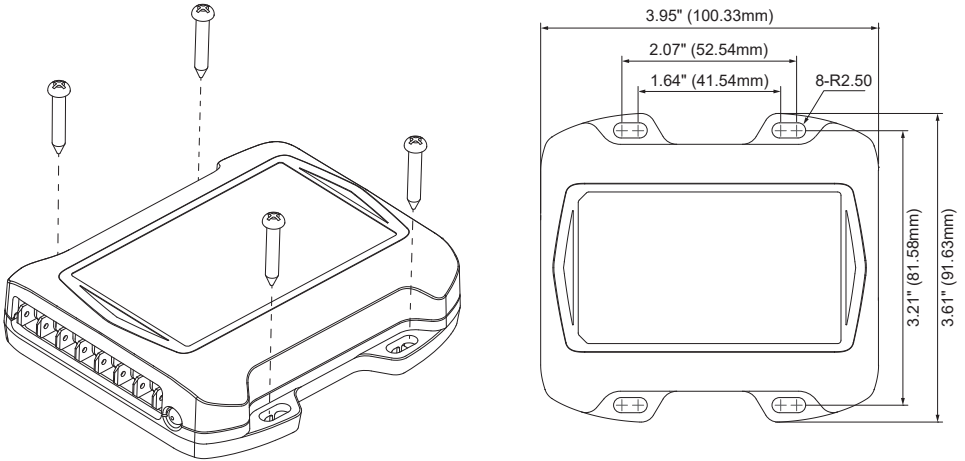

1. Choose a flat surface to install the power module.
2. Use the power module as the template to locate and mark four mounting holes on the mounting surface.
3. Secure the power module with the four #8 self-drilling screws supplied.
NOTE: Always install the power module away from a heat source.

2-1-4. Placement of Decals

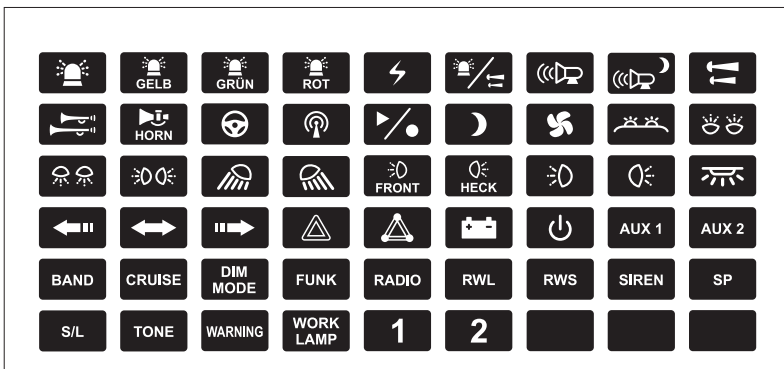

1. The controller is shipped without any button decals installed.
2. After assembling the controller and the mounting bracket, apply a desired decal above each button to facilitate subsequent programming and operation.

2-2. Wiring

2-2-1. Power Module

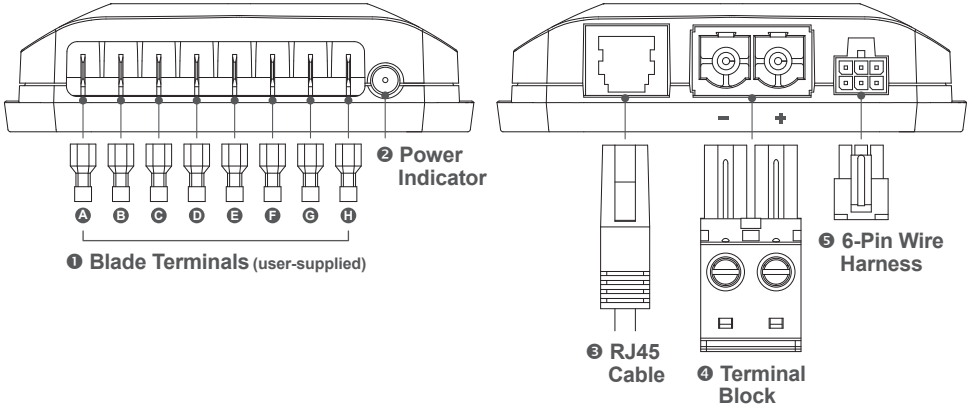

1 Blade Terminals

- A Positive Output 1 (max. 15A)
- B Positive Output 2 (max. 10A)
- C Positive Output 3 (max. 10A)
- D Positive Output 4
- E Positive Output 5
- F Positive Output 6
- G Positive Output 7
- H Positive Output 8

Total current of Output 4~8 is 10A max.

2 Power Indicator

3 RJ45 Cable

4 Terminal Block

5 6-Pin Wire Harness

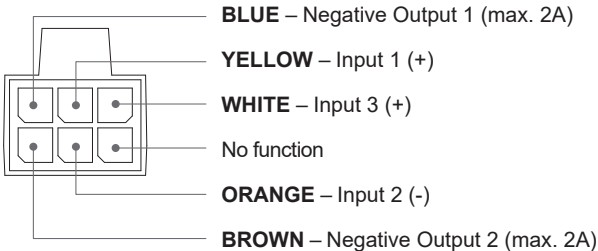

Chapter 3: Programming & Operation

3-1. General Operation for Programming Mode

Programming Mode 1 and Programming Mode 2

SW833 Controller has two programming modes.

Programming Mode 1 allows you to configure B1~B8 and the settings of each input.

Programming Mode 2 allows you to configure the Traffic Arrow function, input configuration of Traffic Arrow, Standby Mode, B4 flashing mode under Standby Mode and Buzzer ON/OFF configuration.

You can also reset to factory default configuration in Programming Mode 2.

Enter a Programming Mode

Press B1 and B3 for more than 1 second to enter Programming Mode 1.

Press B2 and B4 for more than 1 second to enter Programming Mode 2.

NOTE: The indicator light in the upper right corner will flash in single flash for Mode 1, or double flash for Mode 2.

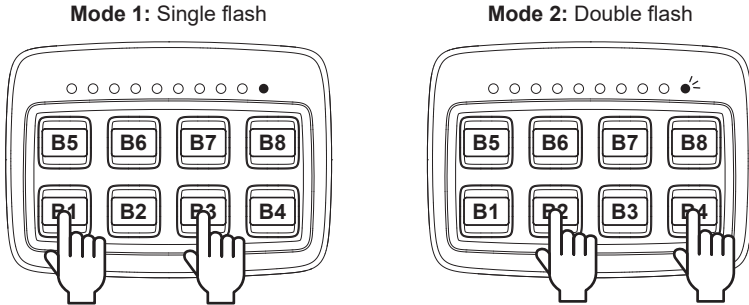

Change Setting Value

1. Press B1 and B3 for more than 1 second to enter Programming Mode 1.
2. Press the button you would like to configure. The indicator light at the upper left corner will be lit up to indicate the current setting (1 light = Setting #1, 2 lights = Setting #2... and so on).
3. Press the button again to go to the next setting. The indicator light will show the current setting according to the rule mentioned above.
4. Press B1 and B3 for more than 1 second to exit and save your configuration.

Error Signal

Under Programming Mode 1 or Mode 2, when you program a button with the function cannot be activated (e.g. B1 has been set as a permanent switch. Configure B3 to activate B1 automatically), an error occurs and the green backlight will flash three times on those buttons with three “beep” sounds.

Reset to Factory Default Configuration

1. Press B2 and B4 for more than 1 second to enter Programming Mode 2.
2. Press and hold B3 and B4 for more than 5 seconds.
3. If SW833 Controller has been restored to factory default configuration successfully, the controller will return to operation mode (after “beep” for three times and green backlight is ON).

Automatic Standby Mode (default configuration)

Automatically enter Standby Mode after 15 minutes if no buttons are activated and Input 1 is not activated either.

(Refer to 3-6 Programming Mode 2, p.19, for detailed information of Standby Mode Configuration)

NOTE: After entering Standby Mode, Programming Mode CANNOT be accessed by default. If you want to enter Programming Mode, disconnect all power and reboot your SW833 Controller.

Testing Mode (for factory users only)

1. Enter Programming Mode 2.
2. Press and hold B7 and B8 for more than 3 seconds.
3. Under Testing Mode, you can test the connection of Input 1 / Input 2 / Input 3 respectively.
4. After finishing testing, disconnect all power to exit Testing Mode.

NOTE: Testing Mode is accessible ONLY under Factory Default Configuration.

3-2. Standby Mode

Enter Standby Mode Automatically (default configuration)

Automatically enter Standby Mode after 15 minutes if no buttons are activated and Input 1 is not activated either.

Enter Standby Mode Manually (default configuration)

Manually enter Standby Mode by pressing B4 for more than 1 second.

It will turn off all button functions.

(Refer to 3-6 Programming Mode 2, p.19, for detailed information of Standby Mode Configuration)

NOTE: After entering Standby Mode, Programming Mode CANNOT be accessed by default. If you want to enter Programming Mode, disconnect all power and reboot your SW833 Controller.

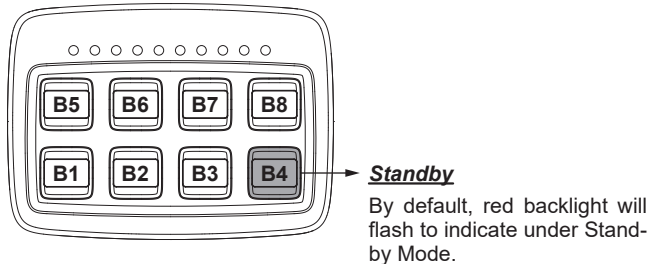

3-3. Default Configuration of Buttons

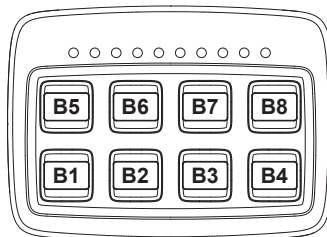

B1 = POSITIVE OUTPUT 1

ON/OFF switch

Activate B1 will activate the main warning light.

When B1 (main warning light) is interlocked by B2 (siren), it is possible to activate B1 by pressing B2.

Also Input 3 can be connected to an external switch to activate B1 (main warning light) and B2 (siren).

B2 = POSITIVE OUTPUT 2 & NEGATIVE OUTPUT 1

Siren Interlock w/ Siren Kill

Connect Input 2 to handbrake.

Activate B2 will activate the siren.

Activate B2 (siren) will also activate B1 (main warning light) simultaneously.

When B2 (siren) is activated, turn on Input 2 (handbrake) will deactivated B2 (siren) immediately.

B3 = POSITIVE OUTPUT 3

Grill warning light kill w/o reverting

Connect Input 2 to handbrake.

Activate B1 (main warning light) will activate B3 (grill warning light) simultaneously.

NOTE: B3 can be activated only when B1 is activated.

When B3 is activated, turn on Input 2 (handbrake) will deactivated B3 immediately.

NOTE: B3 will not revert when input 2 (handbrake) is off.

B4 = POSITIVE OUTPUT 4 & NEGATIVE OUTPUT 2

ON/OFF switch

Activate Positive Output 4 and Negative Output 2.

B5 = POSITIVE OUTPUT 5

ON/OFF switch

Activate Positive Output 5.

B6 = POSITIVE OUTPUT 6

ON/OFF switch

Activate Positive Output 6.

B7 = POSITIVE OUTPUT 7

ON/OFF switch

Activate Positive Output 7.

B8 = POSITIVE OUTPUT 8

ON/OFF switch

Activate Positive Output 8.

Traffic Arrow Indicator Light

No function

NOTE: If you want to configure Traffic Arrow Indicator Light, refer to 3-6 Programming Mode 2 (p.19) to conduct the setting operation.

3-4. Scene 1 and Scene 2 Controlled by B5 and B6

Scene Button Combo: Scene 1

Under Programming Mode 1, you can set B5 as the start button of Scene 1.

While B5 is activated, B1, B2, B3, B4 will be activated simultaneously.

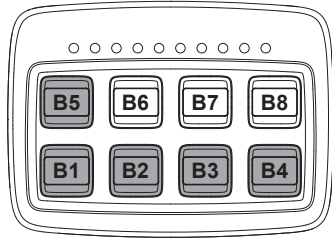
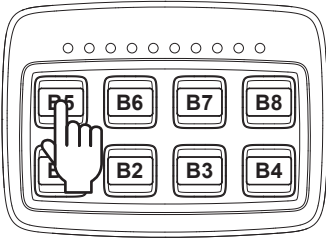

Scene Button Combo: Scene 2

Under Programming Mode 1, you can set B6 as the start button of Scene 2.

While B6 is activated, B1, B3, B4 will be activated simultaneously (B4 can be added or removed in Scene 2 by B4 Setting under Programming Mode 1).

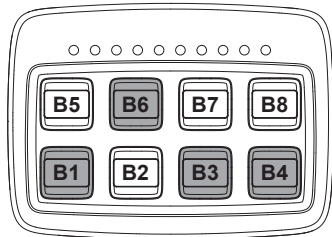
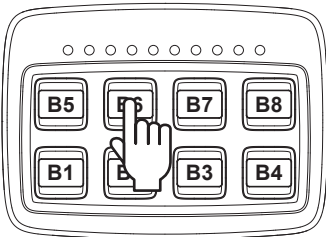

3-5. Programming Mode 1 (for setting B1~B8 button function)

Setting Example: Programming Mode 1

Press B1 and B3 for more than 1 second to enter Programming Mode 1.

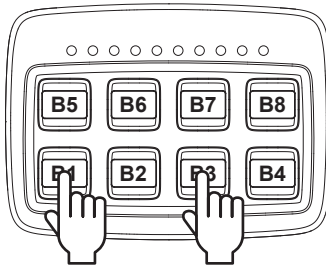

Press B1 once, Setting #2 is currently selected. Press B1 again to go to Setting #3.

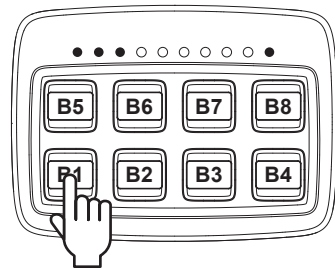
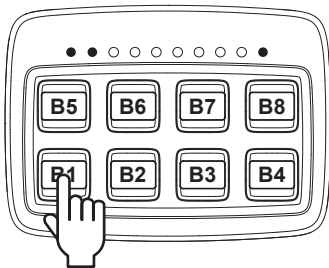

After finishing setting, press B1 and B3 for more than 1 second to exit and save your configuration.

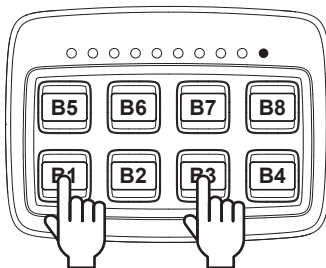

B1 Setting (B1 controls Positive Output 1)

You can use B1 button as an ON/OFF switch that activates the main warning light. B1 may be interlocked by B2 (refer to B2 Setting, p.14).

When B1 (main warning light) is interlocked by B2 (siren), it is possible to activate B1 by pressing B2.

Also Input 3 can be connected to an external switch to activate B1 (main warning light) and B2 (siren).

Enter Programming Mode 1 and configure B1 Setting as the following table:

#	Indicator Light	Description
1	●○○○○○○○○●	Permanent switch, activated upon the power is ON.
2 ★default	●●○○○○○○○○●	ON/OFF switch.
3	●●●○○○○○○●	Momentary switch.
4	●●●●○○○○●	When B1 is activated, input 3 (<u>warning light's status signal</u>) is OFF, B1 will be deactivated after 4 seconds.
5	●●●●●○○○○●	When B2 is activated, input 3 (<u>warning light's status signal</u>) is OFF, B2 will be deactivated after 4 seconds.
6	●●●●●●○○●	Input 3 is connected to an <u>external on/off switch</u> . When the switch is ON, B1 and B2 will be activated. Turn off the switch will deactivate B2.
7	●●●●●●●○○●	Input 3 is connected to an <u>external momentary switch</u> . Press the switch once to activate B1 and B2. Press the switch once again to deactivate B2.
8	●●●●●●●●○○●	Input 3 is connected to an <u>external on/off switch</u> . <u>Only when B1 is activated</u> , turn on the switch will activate B2. Turn off the switch will deactivate B2.
9	●●●●●●●●●●	Input 3 is connected to an <u>external momentary switch</u> . <u>Only when B1 is activated</u> , press the switch once to activate B2. Press the switch once again to deactivate B2.

B2 Setting (B2 controls Positive Output 2 and Negative Output 1)

You can use B2 button as an ON/OFF switch that activates the siren. And B2 may interlock B1, when B1 (main warning light) is interlocked by B2 (siren), it is possible to activate B1 by pressing B2.

Also input 2 can be connected to handbrake or siren status signal to deactivate B2 (siren) for siren kill.

Enter Programming Mode 1 and configure B2 Setting as the following table:

#	Indicator Light	Description
1	●○○○○○○○○●	Permanent switch, activated upon the power is ON.
2	●●○○○○○○●	ON/OFF switch.
3	●●●○○○○●	Momentary switch.
4 ★ default	●●●●○○○○●	<p><i>Siren Interlock w/ Siren Kill</i> Connect Input 2 to handbrake.</p> <ol style="list-style-type: none"> 1. Activate B2 (<u>siren</u>) will also activate B1 (<u>main warning light</u>) simultaneously. 2. When B2 (<u>siren</u>) is activated, turn on Input 2 (<u>handbrake</u>) will deactivated B2 (<u>siren</u>) immediately.
5	●●●●●○○○●	<p><i>Siren Interlock w/o Siren Kill</i></p> <ol style="list-style-type: none"> 1. Activate B2 (<u>siren</u>) will also activate B1 (<u>main warning light</u>) simultaneously. 2. B2 is not affected by Input 2.
6	●●●●●●○○●	<p><i>Siren Interlock w/ Siren status detection</i> Connect Input 2 to siren status signal.</p> <ol style="list-style-type: none"> 1. Activate B2 (<u>siren</u>) will also activate B1 (<u>main warning light</u>) simultaneously. 2. If Input 2 (<u>siren status signal</u>) is OFF, B2 will be deactivated automatically after 4 seconds.
7	●●●●●●●○○●	<p><i>Siren Interlock w/ Siren Kill</i> Connect Input 2 to handbrake.</p> <ol style="list-style-type: none"> 1. B2 (<u>siren</u>) can be activated only when B1 (<u>main warning light</u>) is activated. 2. When B2 (<u>siren</u>) is activated, turn on Input 2 (<u>handbrake</u>) will deactivated B2 (<u>siren</u>) immediately.
8	●●●●●●●●○○●	<p><i>Siren Interlock w/o Siren Kill</i></p> <ol style="list-style-type: none"> 1. B2 (<u>siren</u>) can be activated only when B1 is activated (<u>main warning light</u>). 2. B2 is not affected by Input 2.
9	●●●●●●●●●●●	<p><i>Siren Interlock w/ Siren status detection</i> Connect Input 2 to siren status signal.</p> <ol style="list-style-type: none"> 1. B2 (<u>siren</u>) can be activated only when B1 is activated (<u>main warning light</u>). 2. If Input 2 (<u>siren status signal</u>) is OFF, B2 will be deactivated automatically after 4 seconds.

B3 Setting (B3 controls Positive Output 3)

You can use B3 button as an ON/OFF switch that activates grill warning light and it can be activated simultaneously when B1 (main warning light) is activated.

Enter Programming Mode 1 and configure B3 Setting as the following table:

#	Indicator Light	Description
1	●○○○○○○○○●	Permanent switch, activated upon the power is ON.
2	●●○○○○○○●	ON/OFF switch.
3	●●●○○○○○○●	Momentary switch.
4 ★ default	●●●●○○○○●	<p><i>Grill warning light kill w/o reverting</i> Connect Input 2 to handbrake.</p> <ol style="list-style-type: none"> 1. Activate B1 (<u>main warning light</u>) will activate B3 (<u>grill warning light</u>) simultaneously. <i>NOTE: B3 can be activated only when B1 is activated.</i> 2. When B3 is activated, turn on Input 2 (<u>handbrake</u>) will deactivate B3 immediately. <i>NOTE: B3 will not revert when Input 2 (<u>handbrake</u>) is off.</i>
5	●●●●●○○○○●	<p><i>Grill warning light kill w/ reverting</i> Connect Input 2 to handbrake.</p> <ol style="list-style-type: none"> 1. Activate B1 (<u>main warning light</u>) will activate B3 (<u>grill warning light</u>) simultaneously. <i>NOTE: B3 can be activated only when B1 is activated.</i> 2. When B3 is activated, turn on Input 2 (<u>handbrake</u>) will deactivated B3 immediately. B3 will revert when input 2 (<u>handbrake</u>) is off.
6	●●●●●●○○○○●	<ol style="list-style-type: none"> 1. Activate B1 (<u>main warning light</u>) will activate B3 (<u>grill warning light</u>) simultaneously. <i>NOTE: B3 can be activated only when B1 is activated.</i> 2. B3 is not affected by Input 2.

B4 Setting (B4 controls Positive Output 4 and Negative Output 2)

You can use B4 button as a switch that activates auxiliary devices or rear warning lights.

Enter Programming Mode 1 and configure B4 Setting as the following table:

#	Indicator Light	Description
1	●○○○○○○○○●	Permanent switch, activated upon the power is ON.
2 ★default	●●○○○○○○○○●	ON/OFF switch.
3	●●●○○○○○○○○●	Momentary switch.
4	●●●●○○○○○○●	Connect Input 2 to handbrake. B4 (rear warning light) can be activated <u>automatically</u> only when Input 2 (<u>handbrake</u>) is ON and B1 (<u>main warning light</u>) is activated. Under that circumstance, B4 can be turned on/off manually.
5	●●●●●○○○○●	1. B1 and B4 are mutually exclusive. 2. B4 is not affected by Input 2.
6	●●●●●●○○○○●	When B6 is set as the start button of Scene 2, activate B6 will also activate B1, B3, B4 simultaneously.

B5 Setting (B5 controls Positive Output 5)

You can use B5 button as an ON/OFF switch that activates the traffic arrow function (warning/in-out mode). B5 may be set as the start button of Scene 1 to activate siren and all connected warning lights simultaneously. You can also include B5 into Group 1 or Group 2 to activate traffic arrow function mutually exclusive.

Enter Programming Mode 1 and configure B5 Setting as the following table:

#	Indicator Light	Description
1	●○○○○○○○○●	Permanent switch, activated upon the power is ON.
2 ★default	●●○○○○○○○○●	ON/OFF switch.
3	●●●○○○○○○○○●	Momentary switch.
4	●●●●○○○○○○●	Include B5 into Group 1 button combo. When B6, B7 and B8 are also included in Group 1, B5, B6, B7 and B8 are mutually exclusive.
5	●●●●●○○○○●	Include B5 into Group 2 button combo. When B6, B7 and B8 are also included in Group 2, B5, B6, B7 and B8 are mutually exclusive.
6	●●●●●●○○○○●	Set B5 as the start button of Scene 1. When B5 is activated, B1, B2, B3 and B4 are activated simultaneously. If B5 is the start button of Scene 1 and B6 is the start button of Scene 2, B5 and B6 are mutually exclusive.

B6 Setting (B6 controls Positive Output 6)

You can use B6 button as an ON/OFF switch that activates the traffic arrow function (left-arrow mode). B6 may be set as the start button of Scene 2 to activate all connected warning lights simultaneously. You can also include B6 into Group 1 / Group 2 / Group 3 to activate traffic arrow function mutually exclusive.

Enter Programming Mode 1 and configure B6 Setting as the following table:

#	Indicator Light	Description
1	●○○○○○○○○●	Permanent switch, activated upon the power is ON.
2 ★ default	●●○○○○○○○○●	ON/OFF switch.
3	●●●○○○○○○●	Momentary switch.
4	●●●●○○○○○○●	Include B6 into Group 1 button combo. When B5, B7 and B8 are also included in Group 1, B5, B6, B7 and B8 are mutually exclusive.
5	●●●●●○○○○●	Include B6 into Group 2 button combo. When B5, B7 and B8 are also included in Group 2, B5, B6, B7 and B8 are mutually exclusive.
6	●●●●●●○○○○●	Include B6 into Group 3 button combo. When B7 and B8 are also included in Group 3, B6, B7 and B8 are mutually exclusive.
7	●●●●●●●○○●	Set B6 as the start button of Scene 2. When B6 is activated, B1, B3 and (B4) are activated simultaneously. When B5 is the start button of Scene 1 and B6 is the start button of Scene 2, B5 and B6 are mutually exclusive.

B7 Setting (B7 controls Positive Output 7)

You can use B7 button as an ON/OFF switch that activates the traffic arrow function (center-out mode). You can also include B7 into Group 1 / Group 2 / Group 3 to activate traffic arrow function mutually exclusive.

Enter Programming Mode 1 and configure B7 Setting as the following table:

#	Indicator Light	Description
1	●○○○○○○○○●	Permanent switch, activated upon the power is ON.
2 ★default	●●○○○○○○○○●	ON/OFF switch.
3	●●●○○○○○○●	Momentary switch.
4	●●●●○○○○○○●	Include B7 into Group 1 button combo. When B5, B6 and B8 are also included in Group 1, B5, B6, B7 and B8 are mutually exclusive.
5	●●●●●○○○○●	Include B7 into Group 2 button combo. When B5, B6 and B8 are also included in Group 2, B5, B6, B7 and B8 are mutually exclusive.
6	●●●●●●○○○○●	Include B7 into Group 3 button combo. When B6 and B8 are also included in Group 3, B6, B7 and B8 are mutually exclusive.

B8 Setting (B8 controls Positive Output 8)

You can use B8 button as an ON/OFF switch that activates the traffic arrow function (right-arrow mode). You can also include B8 into Group 1 / Group 2 / Group 3 to activate traffic arrow function mutually exclusive.

Enter Programming Mode 1 and configure B8 Setting as the following table:

#	Indicator Light	Description
1	●○○○○○○○○●	Permanent switch, activated upon the power is ON.
2 ★default	●●○○○○○○○○●	ON/OFF switch.
3	●●●○○○○○○●	Momentary switch.
4	●●●●○○○○○○●	Include B8 into Group 1 button combo. When B5, B6 and B7 are also included in Group 1, B5, B6, B7 and B8 are mutually exclusive.
5	●●●●●○○○○●	Include B8 into Group 2 button combo. When B5, B6 and B7 are also included in Group 2, B5, B6, B7 and B8 are mutually exclusive.
6	●●●●●●○○○○●	Include B8 into Group 3 button combo. When B6 and B7 are also included in Group 3, B6, B7 and B8 are mutually exclusive.

3-6. Programming Mode 2

Setting Example: Programming Mode 2

Press B2 and B4 for more than 1 second to enter Programming Mode 2.

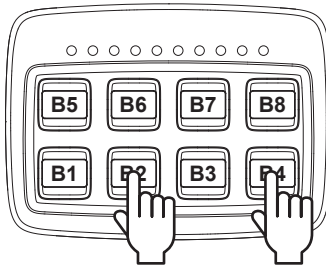

Press B1 once, Setting #2 is currently selected. Press B1 again to go to Setting #3.

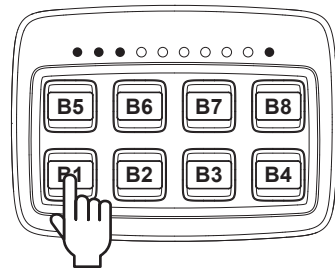
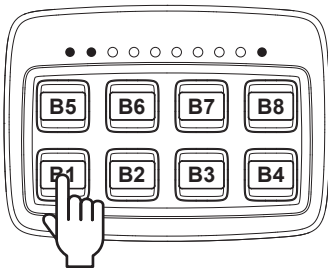

After finishing setting, press B2 and B4 for more than 1 second to exit and save your configuration.

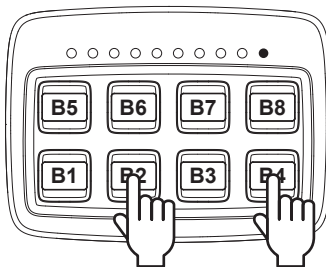

Standby Mode Setting

Under Programming Mode 2, you can change the entry conditions of Standby Mode by B1 Setting.

Enter Programming Mode 2 and configure Standby Mode Setting as the following table:

#	Indicator Light	Description
1	●○○○○○○○○●	Automatically enter Standby Mode after 1 minute if no buttons are activated and Input 1 is not activated. Manually enter Standby Mode by pressing B4 for more than 1 second.
2 ★default	●●○○○○○○●	Automatically enter Standby Mode after 15 minutes if no buttons are activated and Input 1 is not activated. Manually enter Standby Mode by pressing B4 for more than 1 second.
3	●●●○○○○○○●	Automatically enter Standby Mode after 1 minute if no buttons are activated and Input 1 is not activated. Manually turn off all button functions by pressing B4 for more than 1 second first. The red backlight of B4 blinks for 20 seconds and then automatically enter Standby Mode.
4	●●●●○○○○●	Automatically enter Standby Mode after 15 minutes if no buttons are activated and Input 1 is not activated. Manually turn off all button functions by pressing B4 for more than 1 second first. The red backlight of B4 blinks for 20 seconds and then automatically enter Standby Mode.

B4 Flash Setting

Under Programming Mode 2, you can change the flash mode of B4 under Standby Mode by B2 Setting.

Enter Programming Mode 2 and configure B4 Flash Setting as the following table:

#	Indicator Light	Description
1 ★default	●○○○○○○○○●	Set flashing red backlight of B4 to ON (under Standby Mode).
2	●●○○○○○○●	Set flashing red backlight of B4 to OFF (under Standby Mode).

Buzzer Setting

Under Programming Mode 2, you can change the buzzer configuration by B3 Setting.

Enter Programming Mode 2 and configure Buzzer Setting as the following table:

#	Indicator Light	Description
1 ★default	●○○○○○○○○●	Set Buzzer to ON.
2	●●○○○○○○●	Set Buzzer to OFF.

Traffic Arrow Function & Input 2 Setting

Under Programming Mode 2, you can change the configuration of Traffic Arrow function and Input 2 (handbrake) by B5 Setting.

NOTE: Setting #2~#4 are available only when B5, B6, B7, B8 are set as Group1 or Group2.

Enter Programming Mode 2 and configure Traffic Arrow Function & Input 2 Setting as the following table:

#	Indicator Light	Description
1 ★default	●○○○○○○○○●	B5, B6, B7 and B8 are not affected by Input 2.
2	●●○○○○○○●	<i>Traffic arrow can be used when handbrake is ON</i> Connect Input 2 to handbrake. 1. If Input 2 is ON, Group 1 / Group 2 / Group 3 are available for activation. 2. If Input 2 is OFF, B5, B6, B7 and B8 will be deactivated compulsively.
3	●●●○○○○○○●	Connect Input 2 to handbrake. 1. If Input 2 is ON, B5 (<u>warning/in-out mode</u>) will be activated automatically. 2. If Input 2 is OFF, B5~B8 will be deactivated compulsively.
4	●●●●○○○○●	Connect Input 2 to handbrake. 1. If Input 2 is ON and B1 (<u>main warning light</u>) is activated, B5 will be activated automatically. 2. If Input 2 is OFF or B1 is deactivated, B5, B6, B7 and B8 will be deactivated compulsively.

Traffic Arrow Indicator Setting

Under Programming Mode 2, you can change the configuration of Traffic Arrow Indicator by B6 Setting.

NOTE: Setting #2~#4 are available only when B5, B6, B7, B8 are set as Group1 or Group2.

If SW833 Controller has been restored to factory default configuration successfully, the controller will return to operation mode (after “beep” for three times and green backlight is ON).

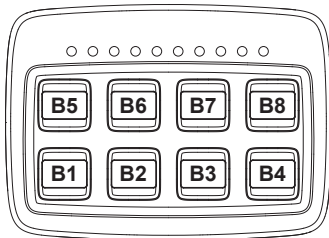

3-7. Button Combo: Group 1

If the B5, B6, B7, B8 are configured in the Group 1, they are mutually exclusive and only one button can be activated at the same time.

B5 controls Positive Output 5.

B6 controls Positive Output 6.

B7 controls Positive Output 6 and 8.

B8 controls Positive Output 8.

NOTE: Positive Output 7 is permanent positive output.

3-8. Button Combo: Group 2

If the B5, B6, B7, B8 are configured in the Group 2, they are mutually exclusive and only one button can be activated at the same time.

B5 controls Positive Output 5.

B6 controls Positive Output 6.

B7 controls Positive Output 7.

B8 controls Positive Output 8.

3-9. Button Combo: Group 3

If the B6, B7, B8 are configured in the Group 3, they are mutually exclusive and only one button can be activated at the same time.

B6 controls Positive Output 6.

B7 controls Positive Output 6, 7 and 8.

B8 controls Positive Output 8.